



Cassetted Blind Profile Dimension Guide

Model	Cassette Size (HxD)	Barrel Size Ø
C45-60	Rounded / Square - 77 x 73mm	40mm
C45-90	Rounded / Square - 105 x 95mm	40 / 45mm

C45 Electric 24v

Features:

The YewdaleDefiant® C45 electric cassette blind with side channels features a low voltage 24v DC motor as standard. This cassette is designed for top or face fixing and accommodates a 40mm grooved aluminium barrel, housing the 24v DC motor. The motor is controlled by a switch which may be surface or flush mounted (not supplied as standard). Fabric is locked into a groove in the barrel with studs fitted at the edge of fabric to retain it within side channels. Aluminium bottom bar. Black or white hardware as standard.

- Quick and easy installation
- Block light with powder coated end plates
- Dedicated support team available to assist with installation and product enquiries
- Blackout options available
- Side channels with integrated tracking system to secure the fabric and minimise light leakage
- Side channel end caps feature pre-drilled lugs for simplified installation

Benefits:

Fingertip control and a slim yet sturdy aluminium frame help this blind lend an air of luxury to any environment and makes the C45 a perfect choice for motorised requirements. Our quiet and reliable motor is housed within the barrel and supported by sturdy, metal brackets. The headbox looks stylish and suits a range of settings. Choose between a rounded or square headbox to complete the blind and protect it from dust and damage.

Enjoy a shorter installation time by following our simple goalpost installation method. Simply connect the side channels to the headbox and install the C45 cassette blind as a frame.

Options:

Square or rounded headbox; Black or white hardware; Remote and/or group control systems in place of single switch; Tracker fabric retaining system; Available in any RAL colour.

Specification:

The YewdaleDefiant® C45-60/90 low voltage electric cassetted blind with side channels as manufactured by Yewdale, +44(0)1268 570900. Flame retardant fabric from the YewdaleDefiant® range, locked into grooved 40mm aluminium barrel along with aluminium bottom bar as standard. Low voltage 24v DC motor is housed within black/white aluminium cassette with side channels and bottom bar. Please note: caution should be used when installing in drafty conditions - blinds should not be left down in the situation of open windows.

Please note the line drawing below is an illustration and the product codes will vary according to headbox size.

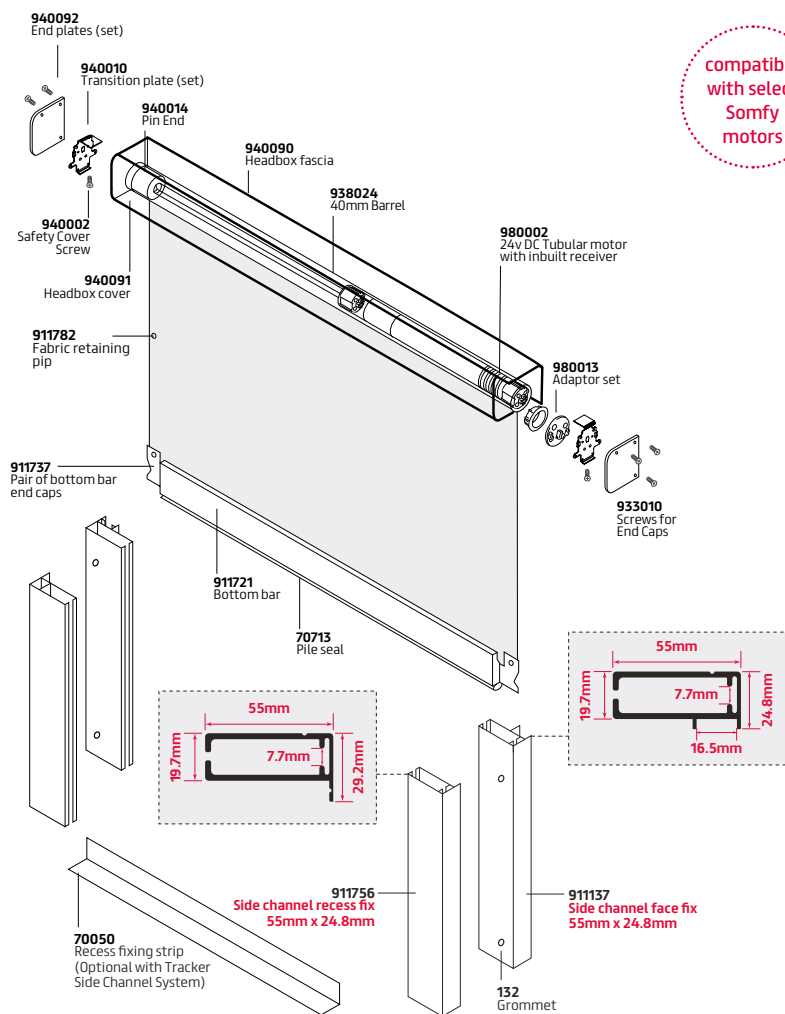

Find this product on
NBS Source



C45T Electric 24v

YewdaleDefiant® Cassetted Blinds

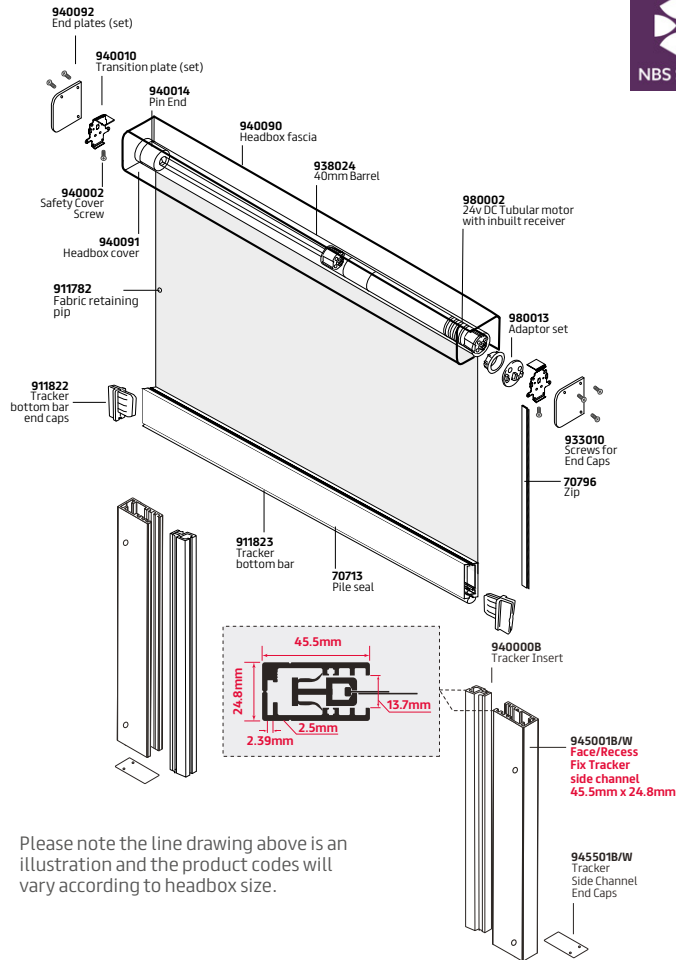

Find this product on NBS Source



Please note the line drawing above is an illustration and the product codes will vary according to headbox size.

C45T Electric 24v

Features:

The YewdaleDefiant® C45T electric cassette blind with side channels features a low voltage 24v DC motor as standard. This cassette is designed for top or face fixing and accommodates a 40mm grooved aluminium barrel, housing the 24v DC motor. The motor is controlled by a switch which may be surface or flush mounted (not supplied as standard). Black or white hardware as standard as standard.

Incorporating the YewdaleDefiant® tracker fabric retaining side channels for vandal-resistant blind alignment, with the functional tracker bottom bar and end caps that complete the system.

- Quick and easy installation
- Block light with powder coated end plates
- Dedicated support team available to assist with installation and product enquiries
- Blackout options available
- Side channels with integrated tracking system to secure the fabric and minimise light leakage
- Side channel end caps feature pre-drilled lugs for simplified installation

Benefits:

Developed to ensure a higher level of tamper-resistance, our tracker side channels ensure the fabric stays secure and prevents movement by air movement or persons around it. This is a popular solution for colleges, schools, libraries etc.

You can choose between a square or rounded headbox to complete the blind and protect it from dust and damage.

You can install our C45T cassette blind using our new goalpost installation technique, which simplifies the installation. Our new end plates allow the side channels to be attached to the headbox and installed as a frame, reducing the installation time.

Specification:

The YewdaleDefiant® C45T Electric 24v as manufactured by Yewdale, +44 (0)1268 570900. Slim aluminium profile with tracker side channels and bottom bar (in black or white) for tamper-resistance. Incorporating a quiet electric motor and flame retardant YewdaleDefiant® fabric.

Cassetted Blind Profile Dimension Guide

Model	Cassette Size (HxD)	Barrel Size Ø
C45T-60T	Rounded / Square - 77 x 73mm	40mm
C45T-90T	Rounded / Square - 105 x 95mm	40 / 45mm

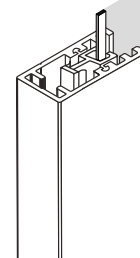

Cassette Headbox

Recommended Installation Clearance

yewdale **Defiant**[®]
FABRIC AND BLIND SYSTEMS

Cassette 60

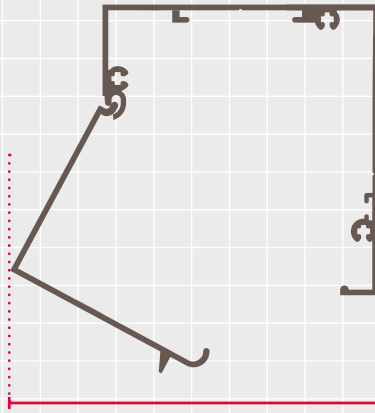

Min. Required: 95mm

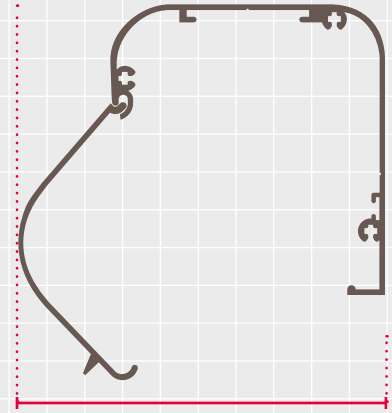

Min. Required: 95mm

Cassette 90

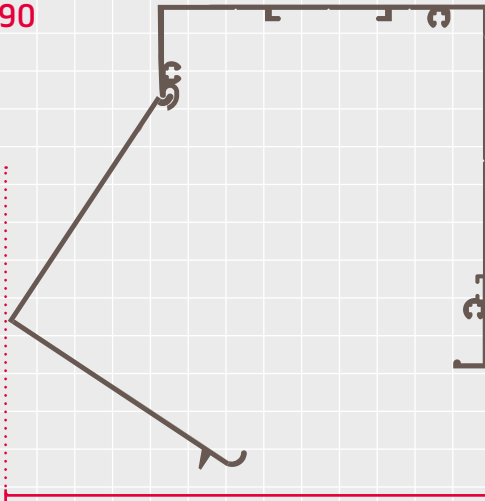

Min. Required: 145mm

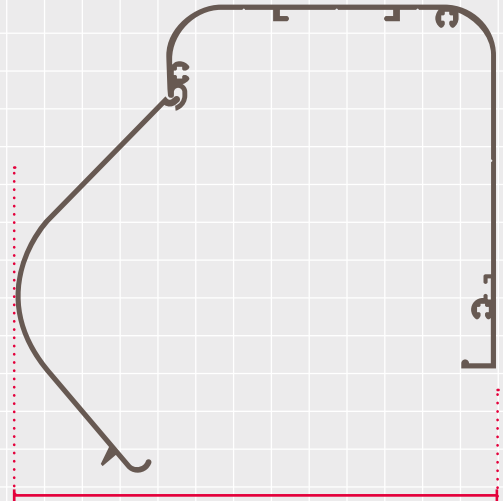

Min. Required: 145mm

Cassette 120

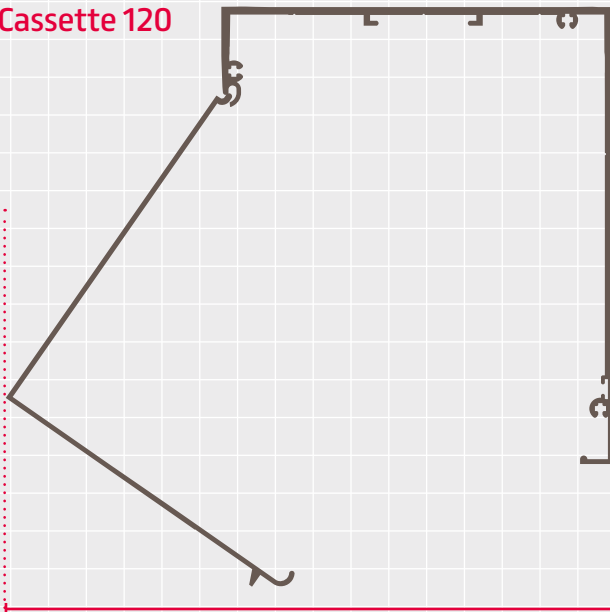

Min. Required: 185mm

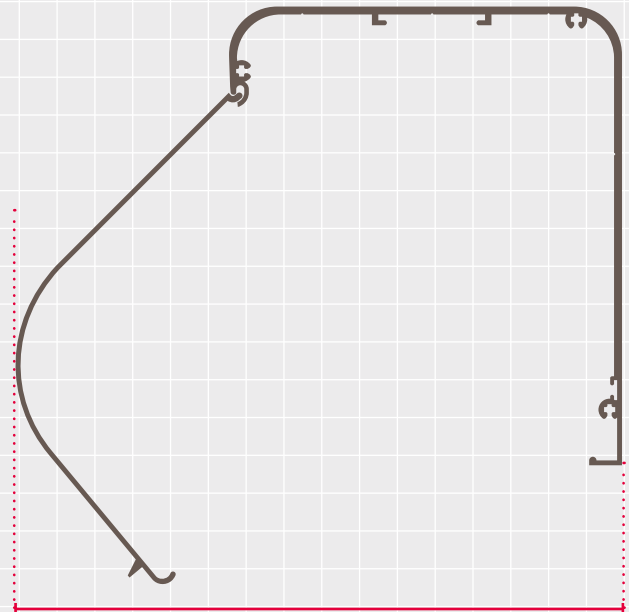

Min. Required: 185mm

All dimensions shown are indicative guidance only. The contractor/installer is responsible for verifying minimum space requirements prior to installation.