



C47 Electric 230v

Features:

The YewdaleDefiant® C47 electric cassette blind with side channels features a motor as standard. The cassette is designed for top or face fix and accommodates a 40mm grooved aluminium barrel, housing the 230v AC motor. The motor is controlled by a switch which may be surface or flush mounted (not supplied as standard). Fabric is locked into a groove in the barrel with studs fitted at the edge of the fabric to retain it within the side channels. Aluminium bottom bar. Black or white hardware as standard.

- Quick and easy installation
- Block light with powder coated end plates
- Dedicated support team available to assist with installation and product enquiries
- Blackout options available
- Side channels with integrated tracking system to secure the fabric and minimise light leakage
- Side channel end caps feature pre-drilled lugs for simplified installation

Benefits:

The C47 offers a premium electric operated cassetted blind for situations where durability and functionality are required. Our square and rounded cassette headboxes look stylish and suits a range of settings. The quiet and reliable motor is housed within the barrel and further protected by the robust aluminium headbox housing. The fabric is locked into the barrel and bottom bar and will give years of trouble-free use. For easy repair or replacement of blind cover, the fabric is located in the groove which allows it to be slid out sideways.

The C47 electric cassette blind benefits from a reduced installation time due to our goalpost installation method. The side channels are connected to the headbox via special end plates, creating a goalpost-shaped frame. The frame is then installed via the side channels.

Options:

Square or rounded headbox; Black or white hardware; Remote and/or group control systems in place of single switch; Tracker fabric retaining system; Available in any RAL colour; Goalpost installation method.

Specification:

The YewdaleDefiant® C47-90/120 electric cassetted blind with side channels as manufactured by Yewdale, +44 (0)1268 570900. Flame retardant fabric from the YewdaleDefiant® range, locked into grooved 53/70mm aluminium barrel along with aluminium bottom bar as standard. 230v AC motor is housed within black/white aluminium cassette with side channels and bottom bar. Please note: caution should be used when installing in drafty conditions - blinds should not be left down in the situation of open windows.

Cassetted Blind Profile Dimension Guide

Model	Cassette Size (HxD)	Barrel Size Ø
C47-90	Rounded / Square - 105 x 95mm	53mm
C47-120	Rounded / Square - 140 x 120mm	53 / 70mm

Please note the line drawing below is an illustration and the product codes will vary according to headbox size.

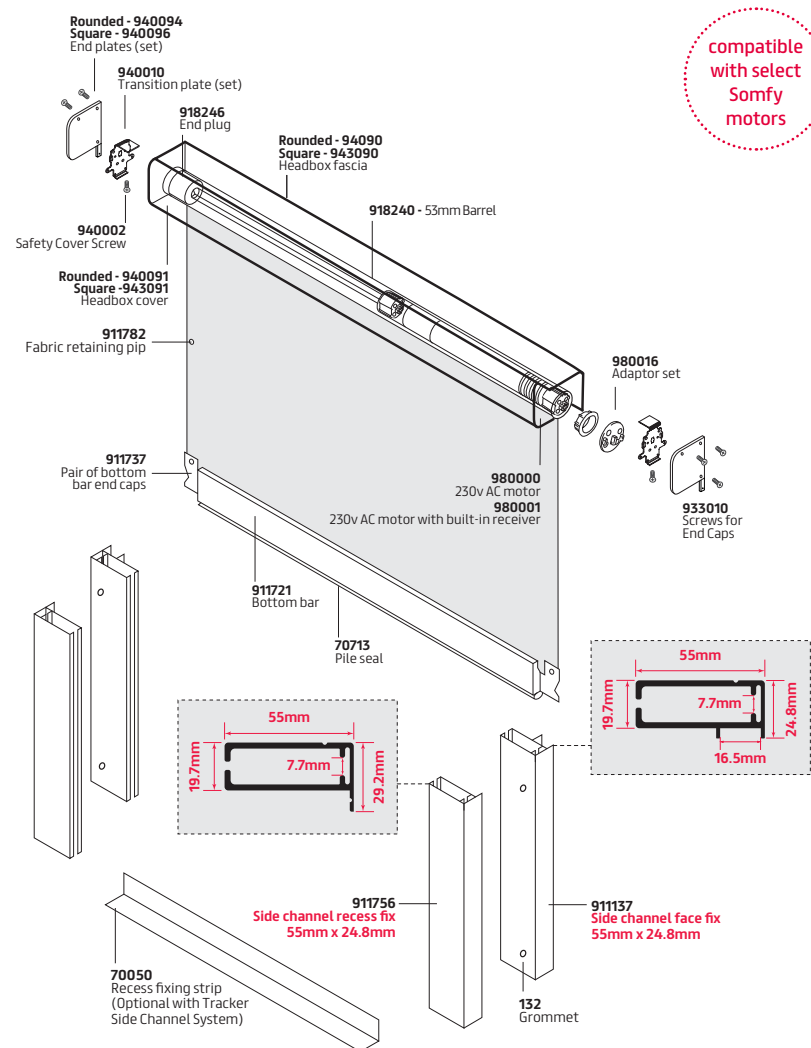

Find this product on
NBS Source



C47T Electric 230v

YewdaleDefiant® Cassetted Blinds

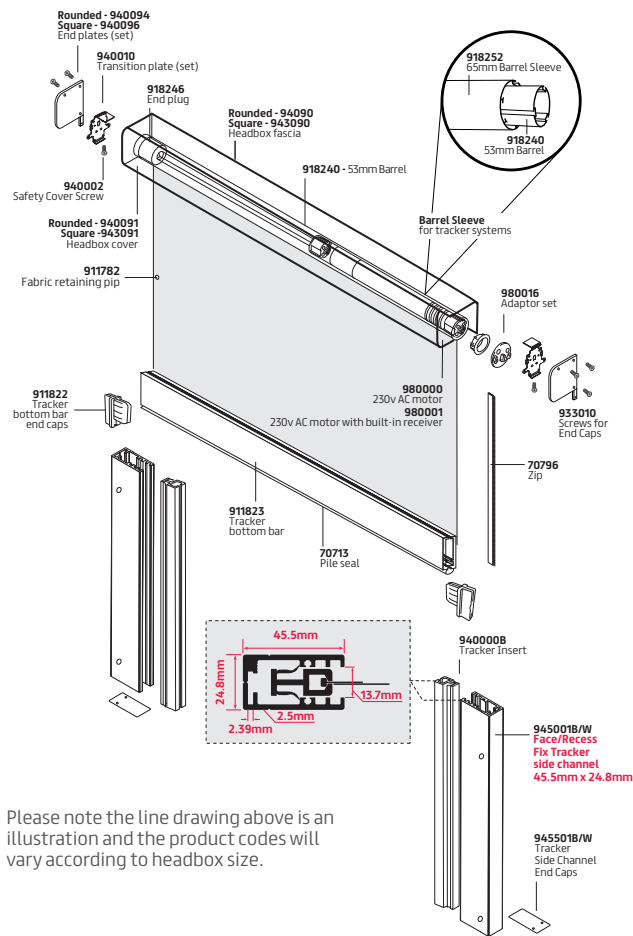

Please note the line drawing above is an illustration and the product codes will vary according to headbox size.



Find this product on NBS Source



C47T Electric 230v

Features:

The YewdaleDefiant® C47T electric cassette blind with side channels features a motor as standard. The cassette is designed for top or face fix and accommodates a 40mm grooved aluminium barrel, housing the 230v AC motor. The motor is controlled by a switch which may be surface or flush mounted (not supplied as standard). Black or white hardware as standard.

Incorporating the YewdaleDefiant® tracker fabric retaining side channels for vandal-resistant blind alignment, with the functional tracker bottom bar and end caps that complete the system.

- Quick and easy installation
- Block light with powder coated end plates
- Dedicated support team available to assist with installation and product enquiries
- Blackout options available
- Side channels with integrated tracking system to secure the fabric and minimise light leakage
- Side channel end caps feature pre-drilled lugs for simplified installation

Benefits:

Developed to ensure a higher level of tamper-resistance, our tracker side channels ensure the fabric stays secure and prevents movement by air movement or persons around it. This is a popular solution for colleges, schools, libraries etc.

You can choose between a square or rounded headbox to complete the blind and protect it from dust and damage.

You can install our C47T cassette blind using our new goalpost installation technique, which simplifies the installation. Our new end plates allow the side channels to be attached to the headbox and installed as a frame, reducing the installation time.

Specification:

The YewdaleDefiant® C47T Electric 230v as manufactured by Yewdale, +44 (0)1268 570900. Slim aluminium profile with tracker side channels and bottom bar (in black or white) for tamper-resistance. Incorporating a powerful 230v AC motor and flame retardant YewdaleDefiant® fabric.

Cassetted Blind Profile Dimension Guide

Model	Cassette Size (HxD)	Barrel Size Ø
C47T-90T	Rounded / Square - 105 x 95mm	53mm
C47T-120T	Rounded / Square - 140 x 120mm	53 / 70mm

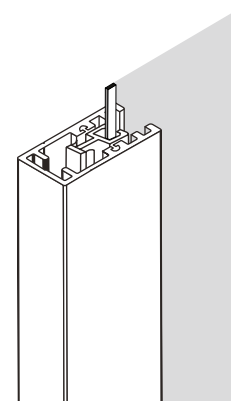

Cassette Headbox

Recommended Installation Clearance

yewdale Defiant[®]
FABRIC AND BLIND SYSTEMS

Cassette 60

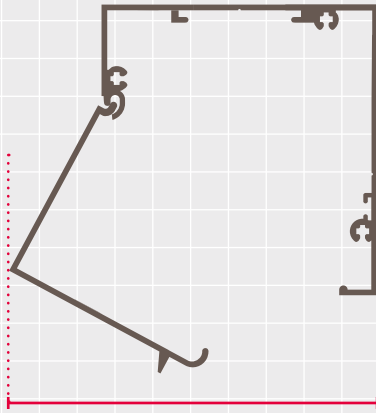

Min. Required: 95mm

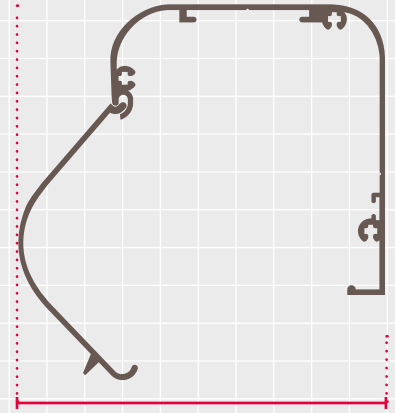

Min. Required: 95mm

Cassette 90

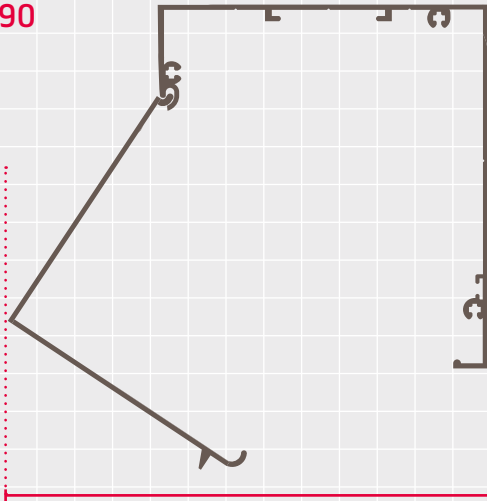

Min. Required: 145mm

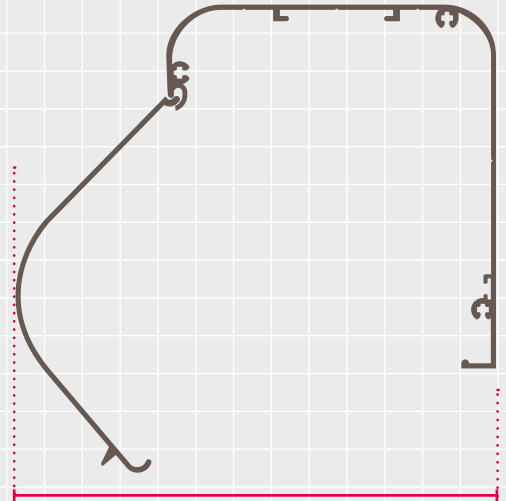

Min. Required: 145mm

Cassette 120

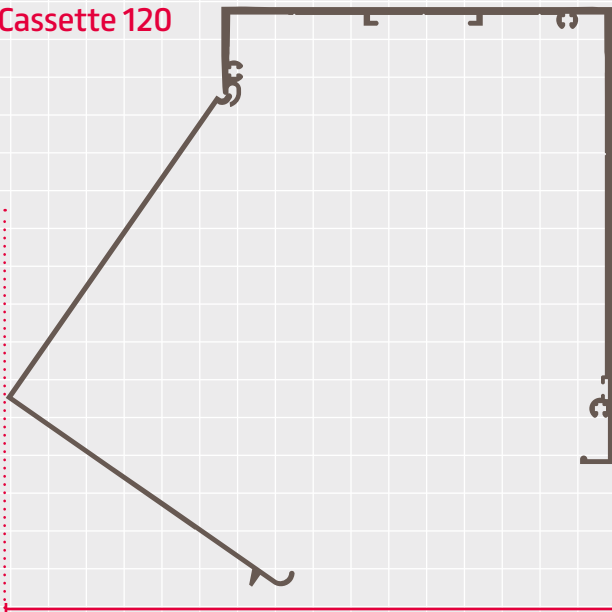

Min. Required: 185mm

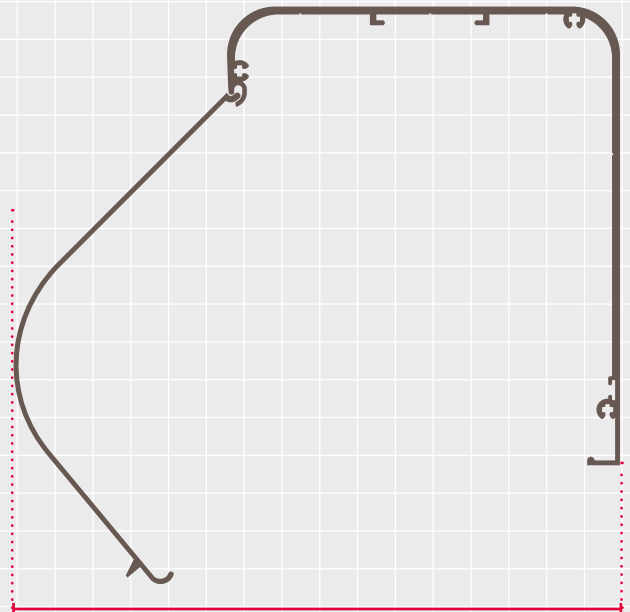

Min. Required: 185mm

All dimensions shown are indicative guidance only. The contractor/installer is responsible for verifying minimum space requirements prior to installation.