



C49 Electric 7.4v

Features:

The YewdaleDefiant® C49 electric cassette blind with side channels features a 7.4v DC battery powered tubular motor. The cassette is designed for top or face fixing which accommodates a 40mm grooved aluminium barrel, housing the motor. The motor makes operation easy thanks to its remote control, with a quiet and soft start/stop motion and electronic stops. The fabric is locked into a groove in the barrel with studs fitted at the edge of the fabric to retain it within the side channels. Aluminium bottom bar. Black or white hardware as standard.

- Quick and easy installation
- Block light with powder coated end plates
- Dedicated support team available to assist with installation and product enquiries
- Blackout options available
- Side channels with integrated tracking system to secure the fabric and minimise light leakage
- Side channel end caps feature pre-drilled lugs for simplified installation

Benefits:

The C49 will keep the fabric looking its best thanks to the protection provided by the square or rounded headbox and tracker side channels ensuring the fabric is taut. The remote control operated motorised elements of this system ensure ease of use and the limit stop functionality provides four intermediate pre-sets the user can set to stop the blind at different levels throughout the day.

The C49 cassette blind is easy to install using our goalpost installation technique. Simply connect the side channels to the headbox and fit the blind via the side channels.

Options:

Square or rounded headbox; Black or white hardware; tracker fabric retaining system; available in any RAL colour.

Specification:

The YewdaleDefiant® C49 electric cassetted blind with side channels as manufactured by Yewdale, +44(0)1268 570900. Flame retardant fabric from the YewdaleDefiant® range, locked into a grooved 40mm aluminium barrel along with an aluminium bottom bar as standard. 7.4v DC motor housed within a black/white aluminium cassette with side channels and bottom bar. Please note: Caution should be used when installing in drafty conditions - blinds should not be left down in the situation of open windows.

Cassetted Blind Profile Dimension Guide

Model	Cassette Size (HxD)	Barrel Size Ø
C49-60	Rounded / Square - 77 x 73mm	40mm
C49-90	Rounded / Square - 105 x 95mm	40 / 45mm

Please note the line drawing below is an illustration and the product codes will vary according to headbox size.

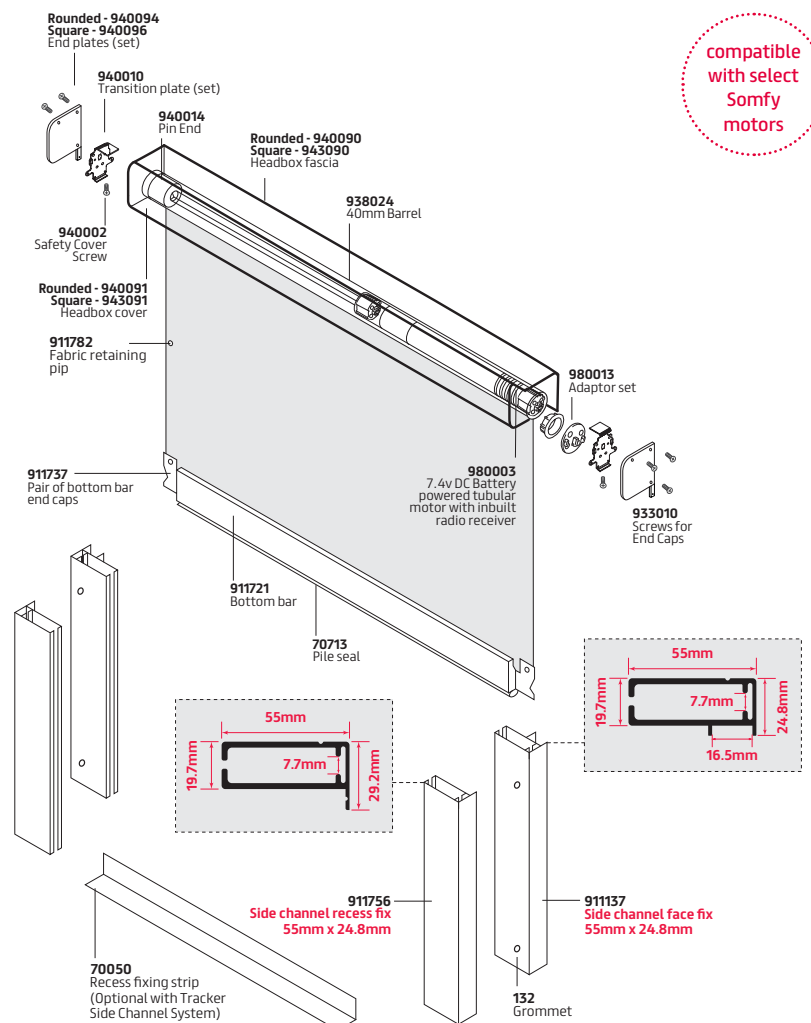

Find this product on NBS Source



C49T Electric 7.4v

YewdaleDefiant® Cassetted Blinds

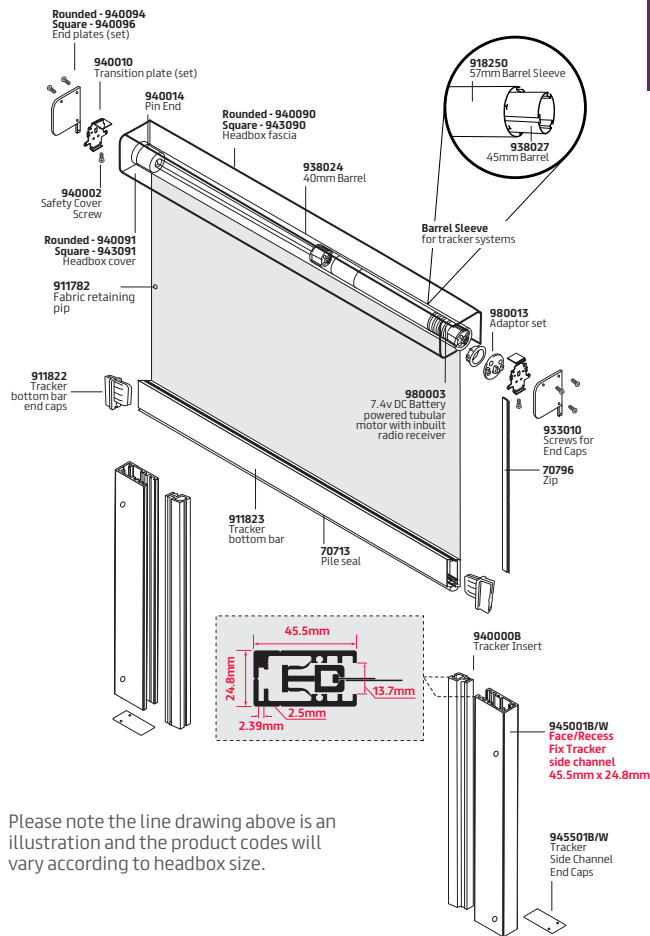

Please note the line drawing above is an illustration and the product codes will vary according to headbox size.



Find this product on NBS Source



C49T Electric 7.4v

Features:

The YewdaleDefiant® C49T electric cassette blind with side channels features a motor as standard. The cassette is designed for top or face fix and accommodates a 40mm grooved aluminium barrel, housing the 7.4v motor. The motor is controlled by a switch which may be surface or flush mounted (not supplied as standard). Black or white hardware as standard.

Incorporating the YewdaleDefiant® tracker fabric retaining side channels for vandal-resistant blind alignment, with the functional tracker bottom bar and end caps that complete the system.

- Quick and easy installation
- Block light with powder coated end plates
- Dedicated support team available to assist with installation and product enquiries
- Blackout options available
- Side channels with integrated tracking system to secure the fabric and minimise light leakage
- Side channel end caps feature pre-drilled lugs for simplified installation

Benefits:

Developed to ensure a higher level of tamper-resistance, our tracker side channels ensure the fabric stays secure and prevents movement by air movement or persons around it. This is a popular solution for colleges, schools, libraries etc.

You can choose between a square or rounded headbox to complete the blind and protect it from dust and damage.

You can install our C49T cassette blind using our new goalpost installation technique, which simplifies the installation. Our new end plates allow the side channels to be attached to the headbox and installed as a frame, reducing the installation time.

Specification:

The YewdaleDefiant® C49T Electric 7.4v as manufactured by Yewdale, +44 (0)1268 570900. Slim aluminium profile with tracker side channels and bottom bar (in black or white) for tamper-resistance. Incorporating a 7.4v motor and flame retardant YewdaleDefiant® fabric.

Cassetted Blind Profile Dimension Guide

Model	Cassette Size (HxD)	Barrel Size Ø
C49T-60T	Rounded / Square - 77 x 73mm	40mm
C49T-90T	Rounded / Square - 105 x 95mm	40 / 45mm

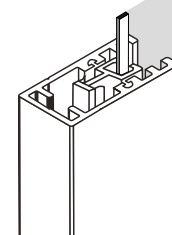

Cassette Headbox

Recommended Installation Clearance

yewdale **Defiant**[®]
FABRIC AND BLIND SYSTEMS

Cassette 60

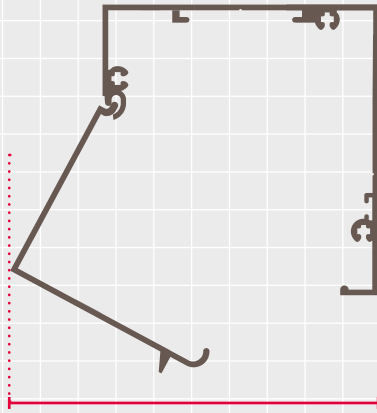

Min. Required: 95mm

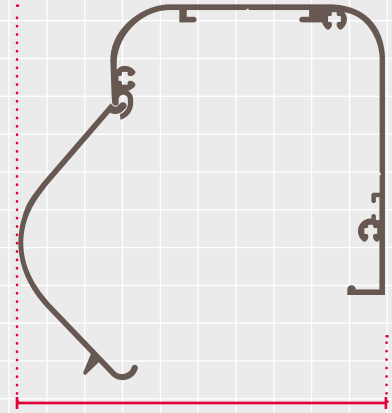

Min. Required: 95mm

Cassette 90

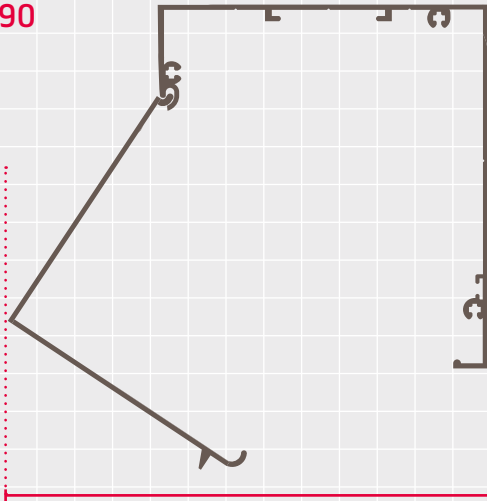

Min. Required: 145mm

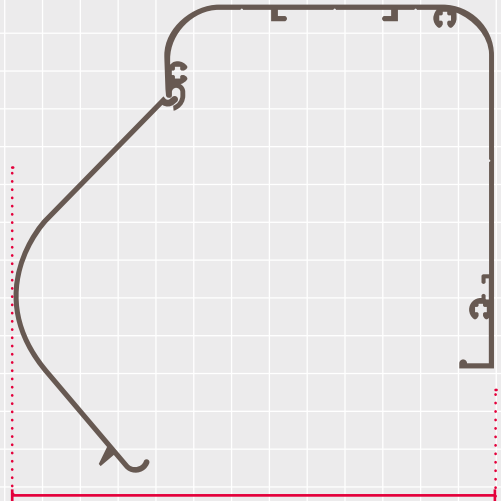

Min. Required: 145mm

Cassette 120

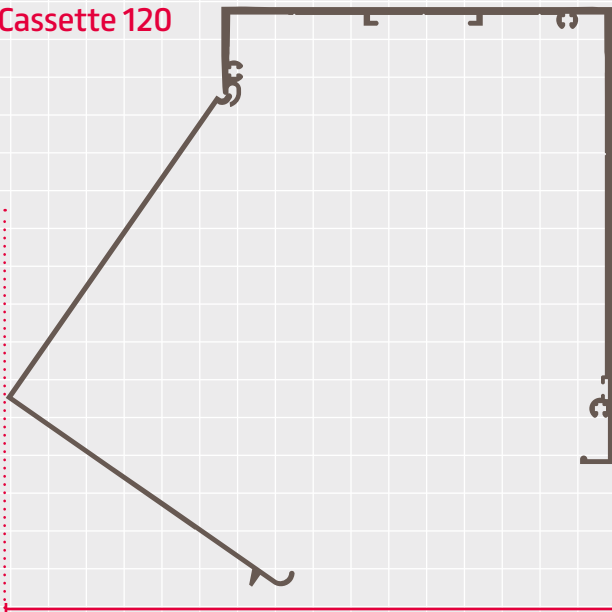

Min. Required: 185mm

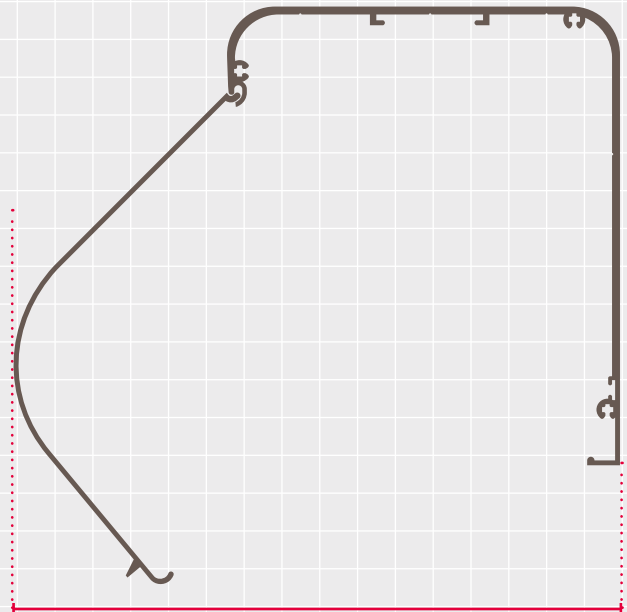

Min. Required: 185mm

All dimensions shown are indicative guidance only. The contractor/installer is responsible for verifying minimum space requirements prior to installation.